

Riding High

IN LAS VEGAS

The line being built in Las Vegas, scheduled to begin operation in January 2004, will represent the first use of a monorail in this country for urban mass transit. Serving the famed resort corridor, it is sure to add to the city's attractions and to provide an agreeable means of travel both to those off to pay their respects to lady luck and to those simply returning home from a day's work. **By Carlos A. Banchik, P.E., and Harry Jasper, P.E.**

The Las Vegas Monorail, now under construction as a mass transit line that will make travel easier for residents and visitors alike along the resort corridor, has its origins in the early 1990s, when the MGM Grand and Bally's hotels began considering an automated people mover to link their two properties.

In 1993 the two resorts decided to join forces and build a monorail that could later be upgraded. Through an international competition, they selected the M-Series Monorail, produced by Montreal-based Bombardier Transportation, as the base technology for the project and contracted with vsl Corporation, of Los Gatos, California, to construct the 0.7 mi (1.1 km) dual-beam, two-station line under a design/build contract. Bombardier Transportation provided MGM Grand and Bally's with the estimated vehicle loading and dynamic characteristics of their M-Series Monorail vehicles, which had been proposed for projects in Houston and Honolulu, and vsl designed the

The five stations being constructed for the line will have two or three levels. The platform lengths will be 243 ft (74 m). Center platforms will be 35 ft (10.6 m) wide, and side platforms will have widths of 20 ft (6.1 m).

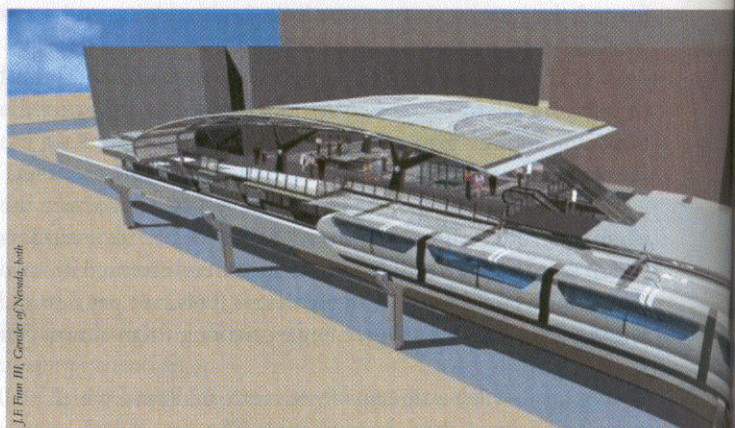

J.E. Finn III, Center of Nevada, Inc.

Las Vegas Monorail

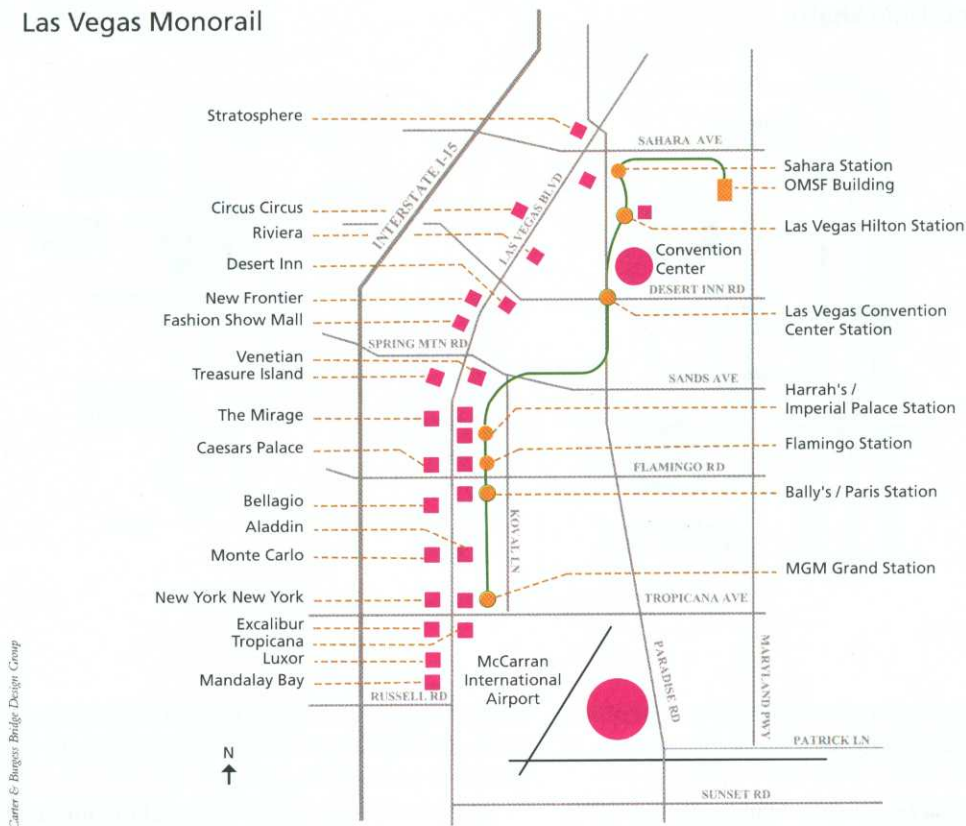

accompanying guideway structure. The two resorts selected this technology because it was seen as lending itself to later expansion and upgrading. Thus it offered the prospect of eventually providing mass transit along the entire Las Vegas resort corridor and taking riders to and from McCarran International Airport.

Two mothballed Mark IV monorail trains built by Bombardier for Walt Disney World, in Orlando, Florida, were purchased and renovated, and the system went into operation in June 1995. Carrying more than 5 million passengers annually, the line connecting MGM Grand and Bally's provided a solid foundation for the Las Vegas Monorail.

In 2000, under a franchise awarded by Clark County to Las Vegas's two largest private resort owners, Park Place Entertainment and MGM Mirage Resorts, the project was fully funded, without the use of tax money of any kind, through the sale of nonrecourse project revenue bonds. In providing more than \$600 million, the bonds provided the capital needed to build the system. No additional funds will be needed for operations or maintenance since those costs are to be covered by the revenue generated. To protect the bondholders and ensure the project's success, the financing arrangement made provision for the following:

- More than \$100 million in interest during and beyond construction;
- Insurance premiums for everything from a county-required "guideway tear-down" guarantee to protection from acts of force majeure;
- Contingencies for such construction unknowns as unidentified underground utilities and differing site conditions;
- Property taxes during construction;
- Management costs for independent oversight of engineering and construction services;
- Reserves amounting to \$75 million to protect the project from any other unforeseen events (above and beyond the protection afforded by the fixed-price contract and insurance).

This approach added significantly to the financing costs, but taking risk out of the bond issuance made it possible for the bulk of the debt to be insured. The bonds achieved a triple-A rating, making them an attractive investment. As a fillip to the financing efforts, the sponsoring resorts (Park Place, MGM Mirage, Harrah's, Imperial Palace, and Sahara) invested a total of \$30 million, and the Las Vegas Monorail Team—a joint venture of Bombardier Transportation and the Watsonville, California, office

Typical Cast-in-Drilled-Hole Shafts

Carter & Burgess Bridge Design Group

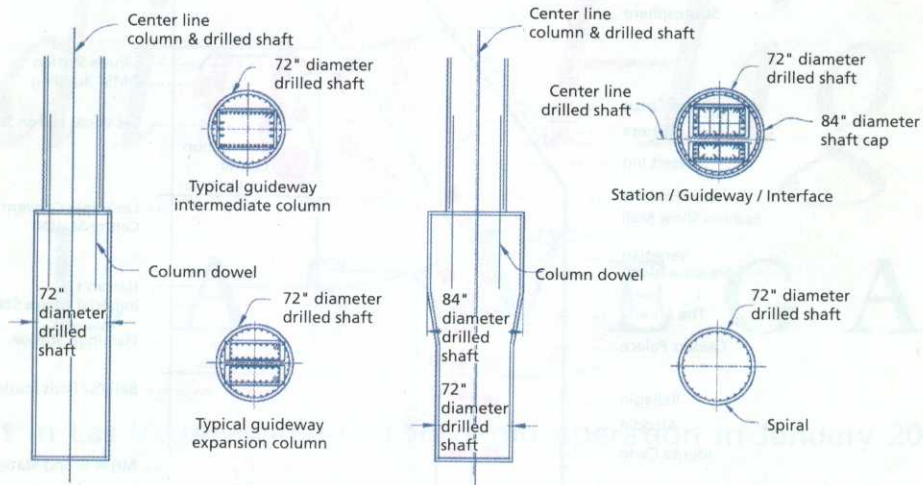

of Granite Construction Company—invested an additional \$18.5 million, for a total private-sector cash investment of \$48.5 million.

The design/build contract was executed in September 2000, and the monorail is scheduled to begin serving the public in January 2004. The owner and operator of the project, the Las Vegas Monorail Company, is a nonprofit quasi-governmental organization set up by the governor of Nevada that for tax purposes qualifies as a 501(c)(4) organization. Transit Systems Management, of Las Vegas, serves as the program manager for the nonprofit corporation. The prime contractor is the Las Vegas Monorail Team. Liaise Corporation—Transmax LLC, also of Las Vegas, serves as the project coordinator for the team. Bombardier also signed a long-term operations and maintenance contract, which will take effect once the system reaches revenue-ready status. All proceeds in excess of the amounts required for operations, maintenance, and debt service must be used to improve or expand the monorail system or to reduce fares.

Now under construction, the system will provide direct service to eight major resort properties as well as to the city's convention center, which is the world's largest. These eight properties together have more than 24,300 hotel rooms. If the areas within a radius of 1,500 ft (450 m) of the stations are included, a total of more than 60,000 hotel rooms will be accessible. The system will be open to the public, so in addition to visitors the tens of thousands of city residents who work along the route will have access to this safe, convenient mode of transport.

The monorail will be extendable at both ends: at the north from the Sahara to downtown Las Vegas and beyond, and at the south from MGM Grand to McCarran International Airport and the west side of the resort corridor. In fact, a decision has already been made to expand the system to the north. Transit Systems Management has been selected by the Southern

Nevada Regional Transportation Commission to extend the monorail to downtown Las Vegas with a spur to connect the system to Las Vegas Boulevard.

With a cost estimated at \$350 million for design, construction, manufacture, installation, testing, and commissioning, the Las Vegas Monorail will extend over almost 4 mi (6.5 km), including the MGM Grand-Bally's segment. It will have seven stations and a dedicated operation, maintenance, and storage facility (OMSF).

The work involving fixed facilities, headed by Granite Construction, involves the design and construction of five new stations, the OMSF, five substations for traction power, and the elevated guideway structure. In addition, the two existing stations (MGM Grand and Bally's) are to be retrofitted and the dual-beam guideway that links them is to be renovated.

The design team for the fixed facilities, headed by the Las Vegas office of Carter & Burgess, Inc. (C&B), recognizes the value of standardization in the design and construction process and is placing special emphasis on the development of solutions and details that can be applied throughout the project.

Under a subcontract to C&B, the Nevada office of the global design firm Gensler has designed the five new stations, as well as the retrofits of the stations at MGM Grand and Bally's. Indeed, it was Gensler that designed those two stations. The five new stations will be of three types: two levels with a center platform, three levels with a center platform, and three levels with side platforms. All have platform lengths of 243 ft (74 m), the center platforms being 35 ft (10.6 m) wide and side platforms having widths of 20 ft (6.1 m).

Two of the new stations (Las Vegas Hilton and Las Vegas Convention Center) have center platforms and only two levels, similar to the MGM Grand and Bally's stations. The foundations and columns of the Las Vegas Convention Center have

Emergency Walkway

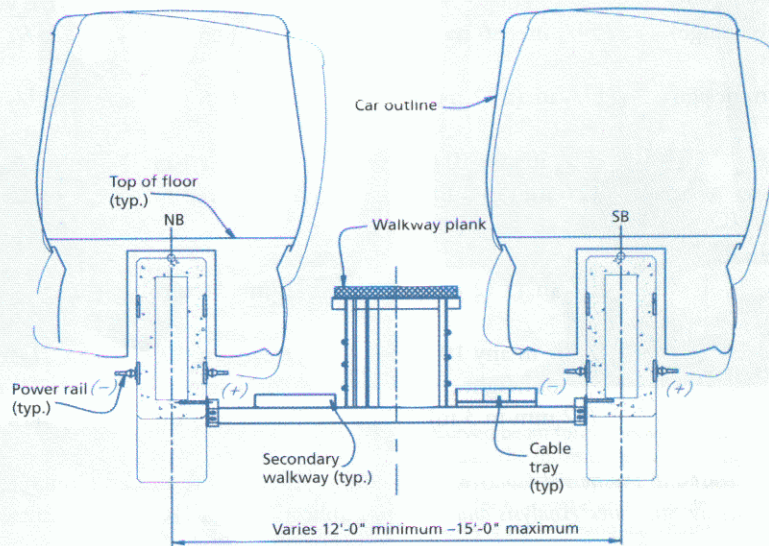

been designed so that at a later date a mezzanine level can be added, possibly to accommodate a commercial lessee. These stations do not require separate mezzanines because their plazas and ticketing areas at ground level provide direct access to the platform level.

Two other stations have center platforms and upper mezzanines but no side platforms. These three-level stations are located over public thoroughfares at the Flamingo Las Vegas and at Harrah's/Imperial Palace. Access to ground level will be provided by pedestrian bridges to the resort properties and by stairs outside the station area for emergency evacuation.

Finally, the new station at the Sahara will have three levels and one of its side platforms will cantilever over Paradise Road. Its mezzanine, on the third level, will be linked to the platforms on the second level. With the exception of the Sahara station, the connections between the station mezzanines and the hotels are the responsibility of the hotel owners. At the Sahara, this connection is being designed and constructed under the baseline contract by the Las Vegas Monorail Team.

All stations will have an open-air configuration with automatic platform door systems. In addition to elevators, escalators, and stairways, the stations will have ticket-vending machines in their mezzanines or lower plaza areas, and there will be closed-circuit television monitoring equipment and public address systems. Architectural treatments of stations can be "customized" by station sponsors or the connecting properties to conform to particular themes, if desired. Advertising revenues being an important component of the project's revenue stream, advertising elements will be integrated into the design of the stations.

C&B designed the OMSF, which is being constructed on a 0.86 acre (0.35 ha) site east of the Sahara station. It is connected to the main line through a spur track having a single guide beam. A simple beam pivot switch provides access to four sep-

arate maintenance bays. The facility's three levels will cover approximately 52,000 sq ft (4830 m²) and include control rooms, store rooms, electrical and mechanical repair shops, administrative offices, and areas for vehicle maintenance. The facility will also house one of the five substations providing traction power.

The elevated guideway consists of 33 linked guideway structural frames and switch structures, the latter including three crossover switches; one Y-junction switch to accommodate expansion of the system to Las Vegas Boulevard and route trains to the OMSF; one turnout switch; and a four-position pivot switch.

The typical guideway structural frame consists of five spans using dual, precast, posttensioned guide beams. The frame is made continuous through cast-in-place closure pours and continuity posttensioning. The minimum clearance over public streets is 18 ft (5.5 m). The spans of the guide beams, which both support and guide the monorail vehicles, average approximately 100 ft (30 m), the longest being about 120 ft (36.6 m). The slender (26 in. [660 mm] wide) haunched beam section varies in depth from 7 ft (2.1 m) at the column supports to 5 ft (1.5 m) at midspan. The space between the guide beams is typically 14 ft (4.2 m) on centers, increasing to 15 ft (4.5 m) in the approaches to crossover switches, and it is even greater in places where the track enters stations with center platforms.

The foundations of the columns supporting the guideway typically consist of concrete cast-in-drilled-hole (CIDH) piles ranging in diameter from 4 to 6 ft (1.2 to 1.8 m). At places where the column size dictates a larger diameter, caisson pile caps are used. The figure on page 70 shows a typical and an enlarged CIDH configuration. At those locations where the monorail alignment actually passes through existing buildings, micropile foundations have been designed to minimize the disruption to hotel operations.

Tolerance	PCI ¹	ACI ²	Las Vegas Monorail
Width of precast piece (gauge)	±1/4 in. (±6 mm)	±1/8 in. (±3 mm)	±1/16 in. (±1.6 mm)
Camber, variation from design	±1/2 in. (±12 mm)	±1/4 in. (±6 mm)	±1/2 in. (±12 mm)
Straightness criteria	±1/4 in. per 10 ft (±6 mm in 3 m)	±1/8 in. per 10 ft (±3 mm in 3 m)	±1/8 in. per 10 ft (±3 mm in 3 m)
Variation in plan, column/beams, structural applications	±1/2 in. (±12 mm)	±1/4 in. (±6 mm)	±1/2 in. (±12 mm)
Variation from plumb	1/4 in. in any 10 ft of height (12 mm in 3 m)	1/8 in. in any 10 ft of height (3 mm in 3 m)	3/8 in. in any 10 ft of height (15 mm in 3 m)

¹PCI Design Handbook: Precast and Prestressed Concrete, fifth edition, Precast/Prestressed Concrete Institute.

²Reinforced Concrete Guideway Structures: Analysis and Design, publication 358.1R-92, Committee 311, American Concrete Institute.

The typical cast-in-place column supports two guide beams over the crossheads. The transverse supporting members, or crossheads, range in height from 4 ft (1.2 m) at the end to 6 ft (1.8 m) directly over the column and are 17 ft (5.1 m) long. The typical column is rectangular with dimensions of 56 by 32 in. (1,422 by 812 mm). A series of reveals and colored sealer impart an attractive architectural look to the columns. The beam-column connection contains a structural steel support and a steel hanger, which, coupled with external supports, make it possible to correctly position each beam during construction. The assembly is such that guideway adjustment and superelevation can be adjusted before pouring.

Unless subjected to nonstandard physical constraints, the columns are centered between the two guide beams, with some adjustments required in areas where the beams are super-elevated. In locations with physical constraints, use is made of eccentric columns, single columns, or straddle bents. The cast-in-place columns typically vary in height from 25 to 30 ft (7.6 to 9.1 m), but in places where the monorail must span an existing pedestrian bridge, as at the Las Vegas Convention Center, the height can reach 60 ft (18.2 m).

The steepest grades (6.5 percent) occur at Bally's Hotel and Casino, where the alignment passes through the second floor of the resort. Steep slopes also occur at the convention center, where, as mentioned previously, the monorail must surmount an elevated walkway that links the center to a parking lot west of Paradise Road. Elsewhere along the route, the grades typically do not exceed 1 percent.

Fully compliant with guidelines set by the National Fire Protection Association, the system has an emergency evacuation walkway along its entire alignment. Located between the two guide beams, the walkway also accommodates the cable tray.

In contrast to the beams used on a typical highway or transit project, the monorail's beams are extremely sensitive to construction defects, since the technology does not allow for second pours to adjust for shortcomings during construction. Each monorail car rides on two vertical tires, one at each end of the car. Each vertical tire in turn is guided by two smaller tires in a horizontal position on either side, making for eight guiding tires per monorail car.

With a side clearance from concrete face to tie reinforcement of approximately 1 in. (25 mm), there is not much room to grind or feather concrete. Correcting problems is all the more difficult because the geometry of the completed structure depends on such external factors as temperature and the position of the sun, which can make repairs to guideway geometry prohibitively expensive.

At the request of the system supplier, Bombardier Transportation, tight tolerances were specified for the construction of the guide beams. The accompanying table compares the project tolerances with those set forth in the *PCI Design Handbook: Precast and Prestressed Concrete*, published by the Precast/Prestressed Concrete Institute, and the publication *Reinforced Concrete Guideway Structures: Analysis and Design*, prepared by Committee 311 of the American Concrete Institute.

The beam geometry is carefully monitored in the precast yard using form control data and an independent total station that surveys the form geometry from a surveying tower built expressly for the purpose. The contractor reviews the geometry once the beams have been cast to ensure compliance with the tolerances given in the table.

During the erection process, surveyors determine the location and elevations of steel supports to make comparisons with theoretical alignment information. After the beams are erected



Lee Stretz, Granite Construction Company



Lee Stretz, Granite Construction Company

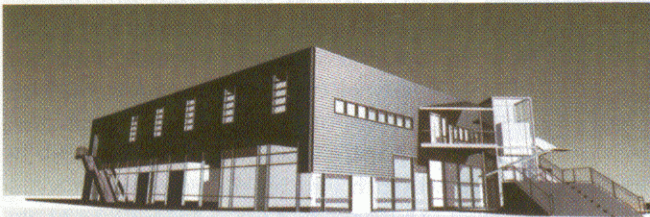

J.F. Finn III, Cosider of Nevada

Curved beam forms, *above left*, were set up at a precast yard in North Las Vegas. The forms have two floating sides, which remain elastic during the casting operations. A series of pipe braces provide the adjustments necessary for horizontal and superelevation control, with vertical control provided by a set of triangular chamfers that serve to strike off the top of the beam. A spur at the north end of the line will convey cars to the operation, maintenance, and storage facility, *left*. A simple beam pivot switch provides access to four separate maintenance bays. The minimum clearance of the guideway, *above right*, over public streets is 18 ft (5.5 m).

and closure pours cast, the contractor again checks the guideway geometry. A special vehicle that can ride along the beams has been designed and constructed to facilitate the surveying work.

In the early stages of the project, the design engineers developed geometric design criteria that were followed during the conceptual and preliminary design phases. The criteria included the minimum radius of curvature (200 ft [61 m]); minimum spiral lengths based on speed and radius of curvature; the maximum superelevation (10 percent); the maximum vertical grade (6.5 percent); and a series of geometric relationships that were to guide the design of horizontal and vertical curves.

AutocAD Land Development, produced by Autodesk, of Sausalito, California, was used to design the geometric alignment. During the conceptual phase, the alignment's geometric constraints, together with political considerations, made it necessary to reduce the minimum radius of curvature from 200 ft (61 m) to an undesirably tight 150 ft (45 m). All curves with a radius of curvature less than 5,000 ft (1,500 m) have been superelevated if the lateral acceleration exceeds 0.06g. The superelevation is created by rotating the beam along the centerline of the riding surface. To reduce the superelevation rate and ensure that passengers experience only centrifugal force at curves, even at speeds lower than the design speed, the beams have been cast in such a way that the superelevations are smaller than the theoretical balanced superelevations. This reduction in superelevation corresponds to a lateral acceleration of 0.06g, the maximum unbalanced superelevation in the project specifications.

During the preliminary phase, a parametric study was carried out to determine the optimal characteristics for the guide

beam and span frame distribution. The optimal configuration was found to be a five-span configuration, with 120 ft (36.5 m) intermediate spans and 100 ft (30.5 m) end spans. The columns at the ends of the frames are hinged in the longitudinal direction so as to minimize moments in the end spans arising from thermal loading while maintaining capacity in the transverse direction. The result is a tuning-fork arrangement, the two columns sharing the drilled shaft foundation.

The project was divided into nine line segments, roughly delimited by the stations. The information required to build the project was contained in two master drawings, one containing alignment data, the other structural data, beam definitions, data on drilled shafts, et cetera. The drawings were accessible by all members of the team but were maintained by only two people, a civil engineer and a structural designer. As of early 2003 there had been nine official revisions to the original alignment. The revisions were necessary to, for example, move stations to accommodate the wishes of participating hotels; insert a Y-junction switch to allow for the possible expansion of the system to Las Vegas Boulevard; realign curves and spirals to accommodate system engineering requests; and carry out realignments in response to surveying work of greater precision. Also, numerous changes in vertical profile were required to accommodate hotel and design parameters as they evolved.

In addition to the master drawings, a set of master spreadsheets was developed, one for each line segment. Master drawings and spreadsheets are carefully monitored to minimize errors in the handling of information. The schedule information was input by engineers and checked for accuracy.

Analysis of the guideway was carried out with the aid of RM2000, structural software developed *(continued on page 86)*

(continued from page 73) by Technische Datenverarbeitung, of Graz, Austria. The software made it possible to model structures in three dimensions and to include construction sequences and time-dependent creep and shrinkage.

Studies were carried out to verify the correlation between theoretical beam deflection and camber and the results obtained in the field. Granite Construction instituted a quality control program that closely tracked the geometry and features of each and every beam.

The contract documents required the contractor to provide infrastructure with a service life of 50 years. The recommendations led to the development of proper concrete mixtures and informed the analysis of creep and shrinkage and of expansion and contraction across joints.

To address the serviceability of the concrete structure, the design team proposed that the contractor use a concrete mix with a water-cement ratio of 0.4 and fly ash admixtures to reduce the permeability of the concrete and increase the serviceability of the mix. The design documents call for beam concrete strengths between 6,000 and 7,500 psi (27.6 and 51.7 MPa), with next-day strengths between 3,500 and 4,200 psi (24.1 and 28.9 MPa) to accommodate posttensioning operations. Field cylinder breaks are consistently reporting 28-day concrete strengths between 9,000 and 12,000 psi (62.0 and 82.7 MPa).

The precast beams are manufactured in a special yard set up by the contractor in North Las Vegas. The site offers easy access to a major highway and there is ample space for storing beams. Helser Industries, of Tualatin, Oregon, manufactured the forms used in the project. The forms, which represent the fourth generation of those developed in 1971 for the monorail at Walt Disney World, have two floating sides, which remain elastic during the casting operations, even with radii of curvature as small as 150 ft (45.7 m) and super-elevations up to 6 percent and radii as large as 200 ft (60.9 m) and super-elevations up to 10 percent. A series of pipe braces provide the adjustments necessary for horizontal and super-elevation control, and vertical control is provided by a set of triangular chamfers that serve to strike off the top of the beam. Because of the tight radii required by the project, an additional set of pipe braces was constructed at the end of the form so that the assembly could cast extremely tight beams without flattening the end sections.

Based on experience gathered in constructing the monorail linking MGM and Bally's, where accelerated curing with gas-fired salamanders caused microcracking of the riding surface, the contractor opted for the Sure-Cure system, developed by Products Engineering, of Boulder, Colorado, which monitors the maturity of concrete by tracking and controlling the temperature inside the forms.

The shafts are drilled using a hydraulic drill rig manufactured by the German firm Bauer Spezialtiefbau. Two 35 ft (10.5 m) deep, 6 ft (1.8 m) diameter shafts can be drilled in a day. The drill rig is particularly effective in drilling through the calcareous layer of caliche, the compressive strength of which can exceed 12,000 psi (82.7 MPa).

After drilling is complete, reinforcement is placed over column dowels, forms are assembled, and columns are poured. Once the column has been poured, the field crews assemble the required crosshead forms and, once again, reinforcement is lowered and concrete poured. The typical column is completed in about 10 days, including curing time.

Once the columns are ready, the beams can be erected, and as many as six beams can be put in place in a given day. Closure pours between the beams at the intermediate columns are prepared and cast. Longitudinal frame posttensioning tendons are stressed, and transverse posttensioning in the intermediate crossheads is then applied. To finalize the construction activities, closure pours in the expansion columns are prepared and poured, including the expansion joint plates that bridge the gap between the two structures.

As the guideway structure is completed, emergency walkways, cable trays, and power rails are installed. The progress made so far by the design/build team on this geometrically complex structure, with its tighter than normal tolerance requirements, augurs well for completion by the scheduled date.

An integrated spreadsheet geometry database developed expressly for the project has provided the data needed for the three-dimensional, time-dependent analysis program, for the production of design drawings, and for survey control of the construction.

The close coordination that has characterized the work of the design/build team has made it possible to develop constructible details that the contractor could use to meet the tight guideway tolerances. The advances made in design and construction on this project will place monorail technology on a footing that will enable it to compete more successfully in the future with other types of transit technology. ■

Carlos A. Banchik, P.E., the engineering manager of the guideway structures on this project, is with Carter & Burgess, Inc., in Las Vegas. Harry Jasper, P.E., is the engineer of record and manager of the bridge design group in the Denver office of Carter & Burgess. This article was adapted from a paper presented at the 2002 Concrete Bridge Conference, which was held in Nashville, Tennessee, October 6–9 under the joint sponsorship of the National Concrete Bridge Council and the Federal Highway Administration.

PROJECT CREDITS

Project owner: Las Vegas Monorail Company, Las Vegas

Contract manager: Transit Systems Management, Las Vegas

Prime contractor: Las Vegas Monorail Team—a joint venture of Bombardier Transportation, Montreal, and Granite Construction Company, Heavy Construction Division, Watsonville, California

Project developer/coordinator: Liaise Corporation—Transmax LLC, Las Vegas

Fixed facilities designer: Carter & Burgess, Inc., Las Vegas

Station designer: Gensler of Nevada, Las Vegas

Form manufacturer: Helser Industries, Tualatin, Oregon